

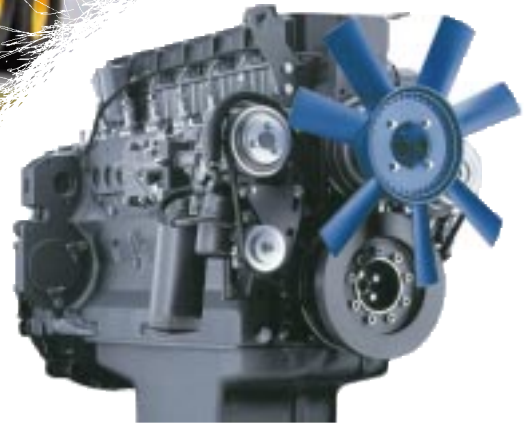

# 1013 E. The engine for agricultural equipment.



90-186 kW at 2300 rpm



## These are the characteristics of the 1013 E:

Modern water-cooled 4- and 6-cylinder in-line engine  
Turbocharging with charge air cooling (BFM1013EC/P)  
High-pressure fuel injection up to 1600 bar  
Electronic engine governor with diagnostic facilities as option  
100 % PTO capability at flywheel end and front end  
Three options for installation of gear-driven hydraulic pumps  
Long maintenance intervals and user-friendly maintenance design  
Customer service available worldwide

## These are the benefits for you:

- ▶ High productivity through dynamic power development
- ▶ Quietest engine of its class and high degree of operating comfort
- ▶ Low exhaust emission for a clean environment
- ▶ High reliability even under extreme working conditions, and long service life
- ▶ Low fuel consumption and low maintenance costs mean savings in operating costs

## Engine description

Type of cooling:	Liquid cooling, thermostatically controlled, charge-air-cooled engines with air-to-air charge air cooler*
Crankcase:	Grey cast iron crankcase, for monobloc construction, wet liners
Crankcase breather:	Closed circuit crankcase breather
Cylinder head:	Grey cast iron block-type cylinder head
Valves/drive train:	One inlet and one exhaust overhead valve per cylinder, drive through tappets, push rods and rockers; gear-driven camshaft
Pistons:	Three ring pistons, two compression rings and one oil scraper ring
Piston cooling:	Oil cooled with spray nozzles
Connecting rod:	Forged steel rod
Crankshaft bearings:	Laminated plane bearings
Crankshaft:	With integral counter weights: 4-cylinder version with integral mass balancing shafts
Camshaft:	Forged steel
Lubricating oil:	Pressure system with integral-gear pump
Lubricating oil cooler:	Integral oil to water heat exchanger
Lubricating oil filter:	Canister type paper element full flow filter
Fuel pump/governor:	Single injection pumps for each cylinder set into crankcase Mechanical centrifugal governor (standard); electronic engine governor (EMR) optional
Fuel lift pump:	Integrated in v-belt tensioner
Injection nozzle:	Six-hole nozzle
Fuel filter:	Replaceable element
Alternator:	Three-phase alternator 12 V or 24 V
Starter motor:	12 V or 24 V
Cab heating:	Connections for cab heating in the engine cooling system
Accessoires:	Combustion air inlet connections, exhaust connections, positioning of turbocharger, air compressors, hydraulic pump PTOs, SAE 2/3/4/ flywheel housings, flywheels, 12 V or 24 V electrics, oil pans, cold start aids

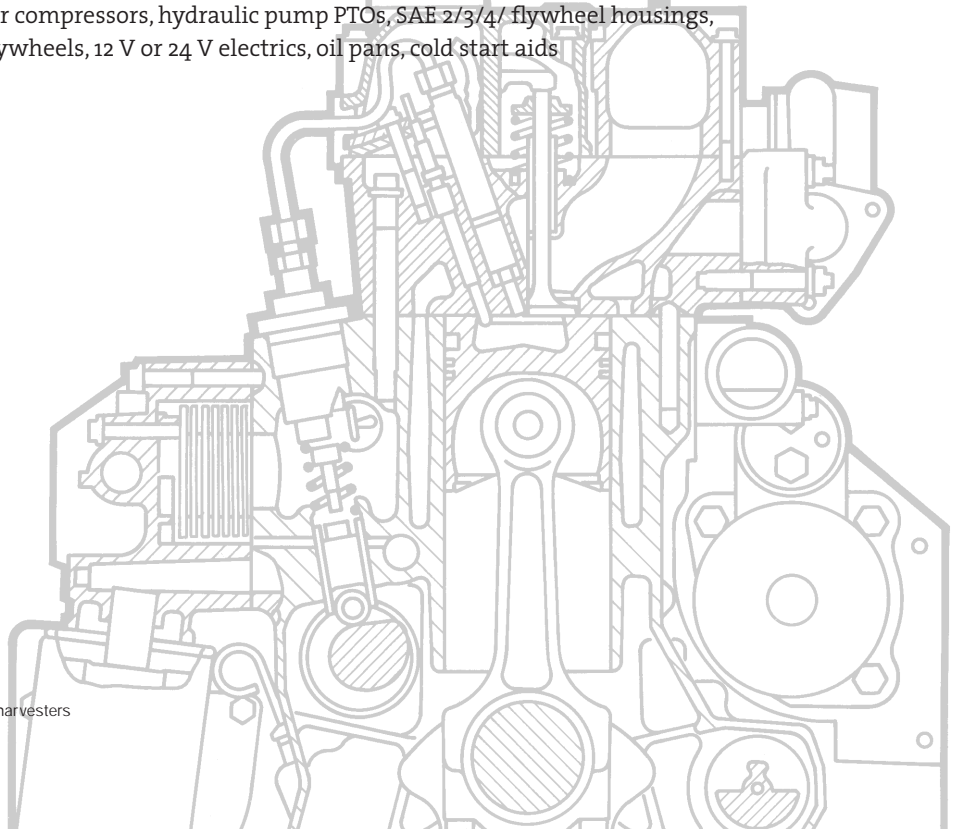

\* Alternatively with integrated cooling for harvesters

## ► Technical data

Engine Type		BF4M1013E	BF4M1013EC	BF6M1013E	BF6M1013EC
Number of cylinders		4	4	6	6
Bore/stroke	mm	108/130	108/130	108/130	108/130
Displacement	l	4.764	4.764	7.146	7.146
Compression rate		17.6	17.6	17.6	17.6
Max. rated speed	rpm	2300	2300	2300	2300
Mean piston speed	m/s	9.97	9.97	9.97	9.97
<b>Power ratings for tractor engines<sup>1)</sup></b>					
Power rating to ISO 3046/1	kW	90	115	137	165
at speed	rpm	2300	2300	2300	2300
Mean effective pressure	bar	9.86	12.59	10.00	12.05
Max. torque	Nm	468	577	702	854
at speed	rpm	1400	1400	1400	1400
Minimum idle speed	rpm	800	800	800	800
Specific fuel consumption <sup>2)</sup>	g/kWh	208	200	208	208
Weight to DIN 70020, part 7A <sup>3)</sup>	kg	430	432	570	572

## ► Dimensions

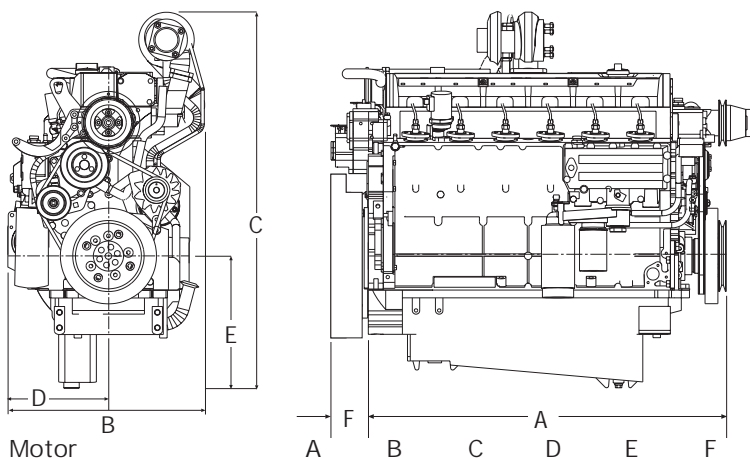

Motor		A	B	C	D	E	F
BF4M1013E <sup>4)</sup>	mm	762	593	986	312	295	122
BF4M1013EC <sup>4) 5)</sup>	mm	762	593	986	312	295	122
BF6M1013E	mm	1055	574	1001	281	387	122
BF6M1013EC <sup>5)</sup>	mm	1055	574	1001	281	387	122
BF6M1013ECP <sup>5)</sup>	mm	1055	574	1001	281	387	122

## ► Model designation

BF 6 M 1013 E

C = with charge air cooler  
E = with external cooling system  
P = Uprating

Piston stroke

Serial index

Liquid cooled

Number of cylinders

B = Exhaust turbocharging  
F = High-speed four-stroke engine

- Power ratings without deduction fan power requirement
  - Specific fuel consumption at optimal operating point based on diesel fuel with a density of 0,835 kg/dm<sup>3</sup> at 15°C.
  - Without starter motor/alternator, radiator and liquids, however with flywheel and flywheel housing.
  - For monobloc construction, please check with DEUTZ AG
  - Dimensions without charge air cooler, side mounted turbocharger optional.
- \*) with controlled exhaust turbocharger  
These values are only for your information and not binding.

## ► Standard engines

### BF6M1013ECP

6

108/130

7,146

17,6

2300

9,97

186

2300

13,58

954\*

1400

800

200

572

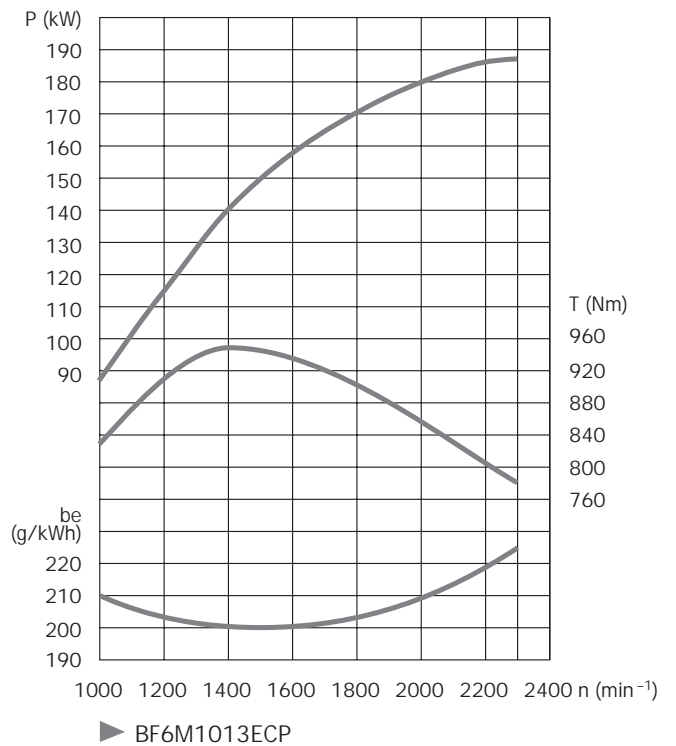
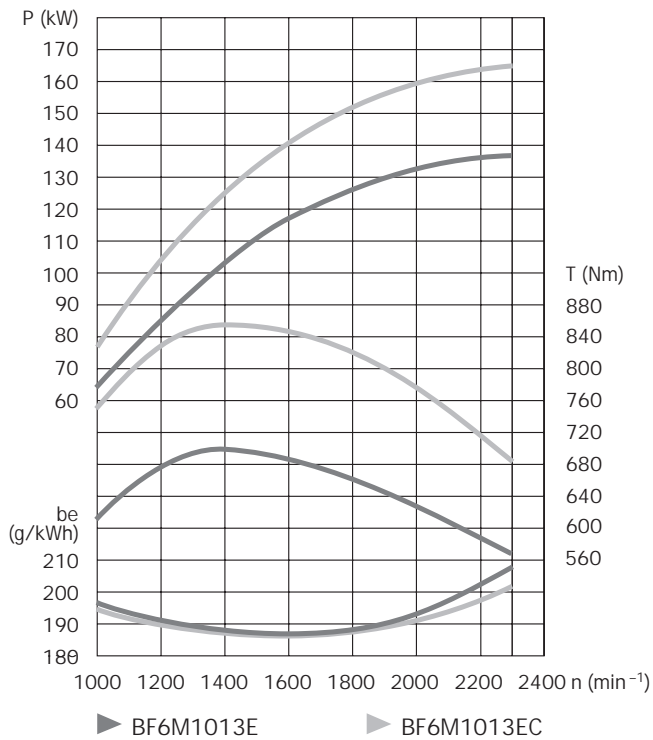
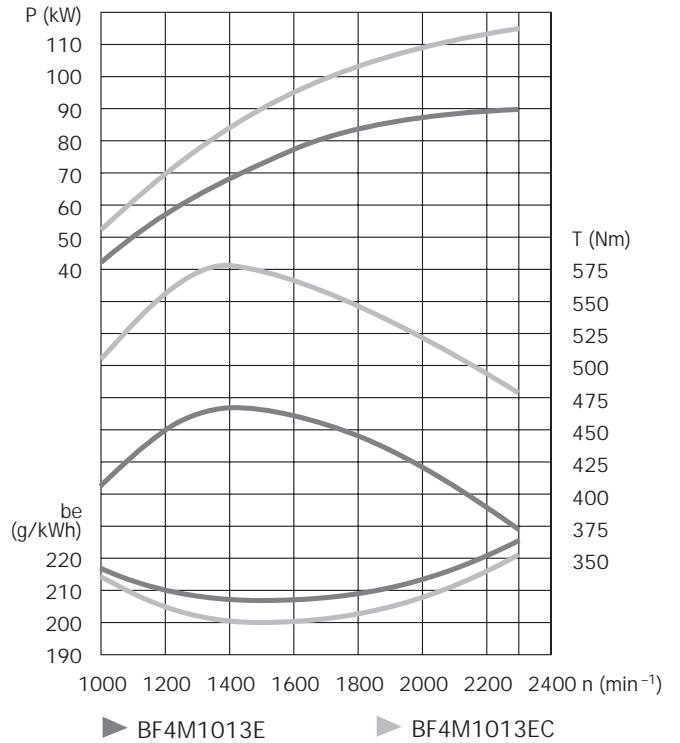

## ▶ Tractor engines

Mechanical and electronic governor (EMR) allow customisation of torque and power curves.

Torque back up of 30% and more is possible.

Drive-away torque of 110% rated torque at 1000 min<sup>-1</sup>.

The engines meet all current and planned exhaust emissions legislations.

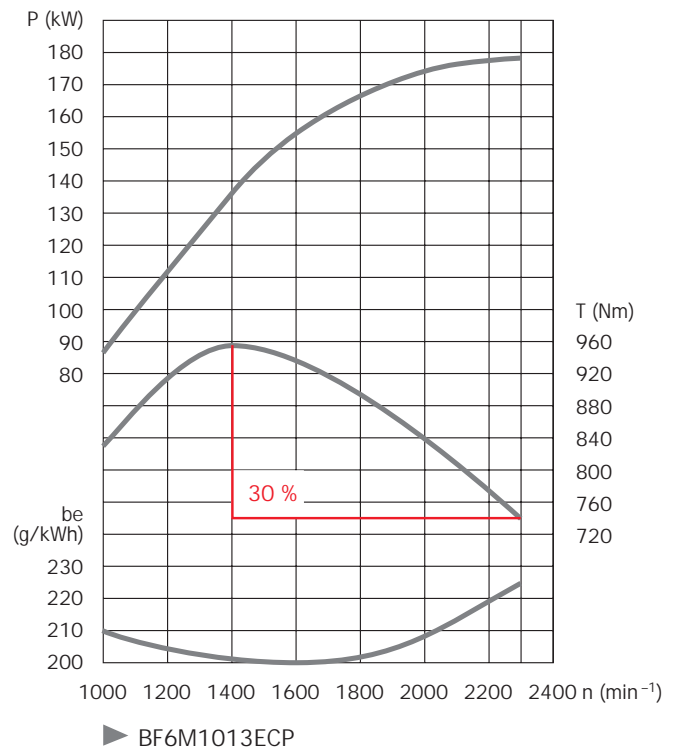
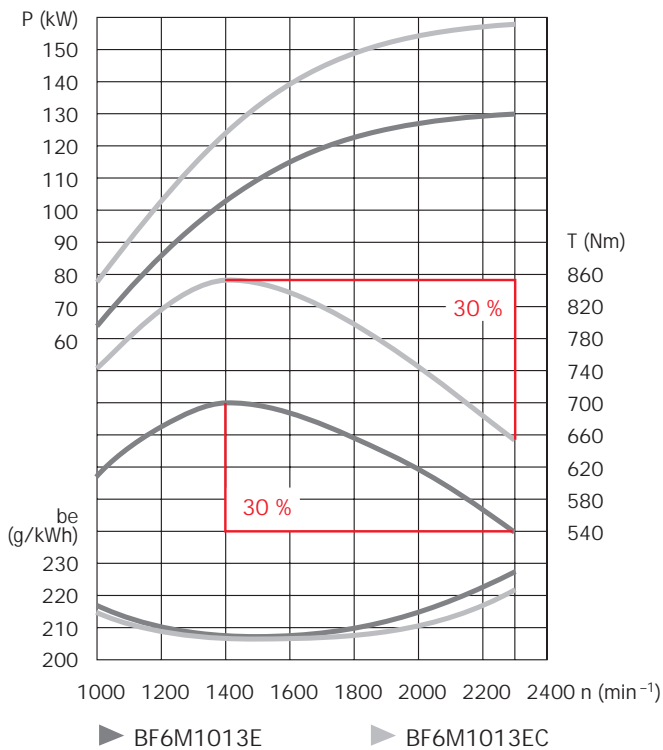
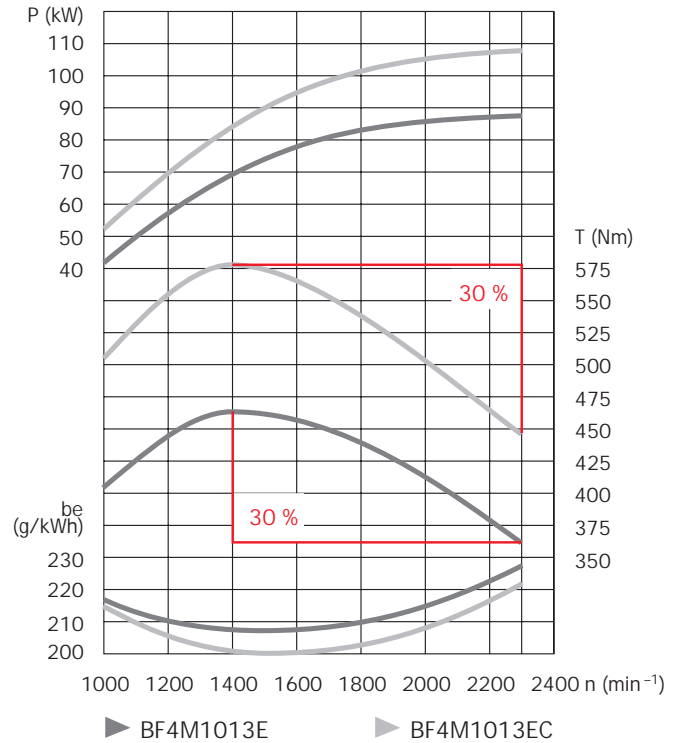



**Knowing it's DEUTZ.**

**DEUTZ AG**

Deutz-Mülheimer Str. 147-149

D-51057 Köln

Tel.: ++ 49 (0) 2 21-8 22 - 25 10

Fax: ++ 49 (0) 2 21-8 22 - 25 29

Internet: <http://www.deutz.de>



**Blue Ridge Diesel**  
1016 Delaware Street  
P.O. Box 867, Salem, VA 24153

PHONE (540) 389-7296 - FAX (540) 387-2792



**Blue Ridge Diesel** is one of the leading import diesel engine houses on the east coast of the U.S. Our sales department personnel are qualified to assist you in the proper sizing and selection of an engine for your application. Whether you are working with industrial, construction, agricultural, marine, or mining equipment, our knowledgeable people can help in many ways. From equipment repowering to specifying an engine for new equipment, our competent sales staff is ready to assist you and answer any questions you may have.

### Contact Info:

[info@blueridgediesel.com](mailto:info@blueridgediesel.com)

540-389-7296



**Blue Ridge Diesel**  
1016 Delaware Street  
P.O. Box 867, Salem, VA 24153

PHONE (540) 389-7296 - FAX (540) 387-2792

