

ISUZU 4LE2

52.4 Horsepower
Industrial Diesel

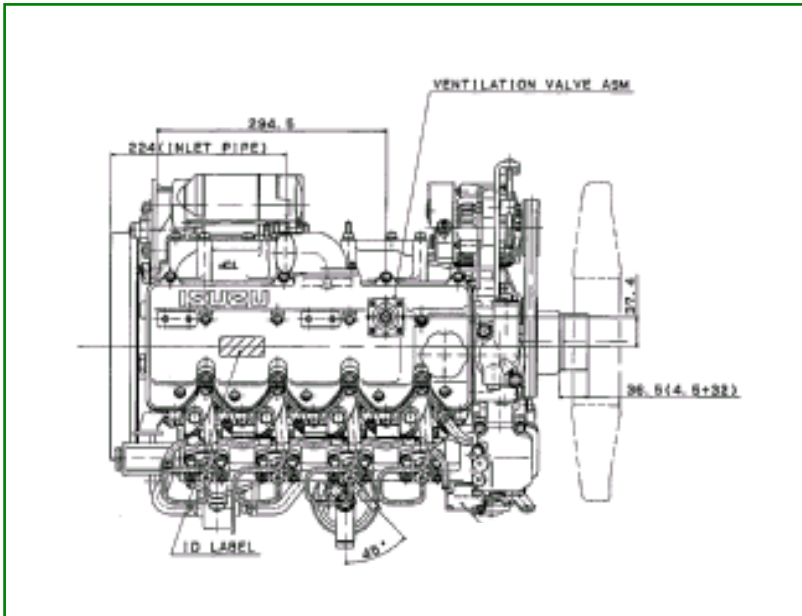

MAIN SPECIFICATIONS

Type	4-Cylinder, 4 Cycle, Water Cooled, OHV, In-Line, Direct Injection
Bore & Stroke	3.35 x 3.78 in. (85mm x 96mm)
Engine Displacement	2.2 L
Compression Ratio	18.8:1
Dry Weight	299 lbs. (135.5 kg)
Dimensions (L x W x H)	25.7 x 19.2 x 23.7 in. 654 x 488 x 602 mm
Coolant Capacity	3.0 qt. (2.8 L)
Lube Oil Capacity	8.6 qt. (8.1 L) (less filter)

MAIN FEATURES

Alternator	12V – 35A
Voltage Regulator	Internal
Starter	12V – 2.0kW
Exhaust Outlet	Sideward
Air Inlet	Rearward Upward
Flywheel Housing	Flat Rear Plate
Flywheel	Thin SAE Type for 7.5" Over Center Clutch
Oil Pan	30° Inclination All Directions
Fan	15.7 in. (400mm) Suction

INDUSTRIAL RATING*

Rated Output	52.4 BHP @ 3000 RPM
Max Torque	105 lb. ft. @ 2250 RPM

*SAE J1995 Gross BHP

Specifications subject to change without notice.

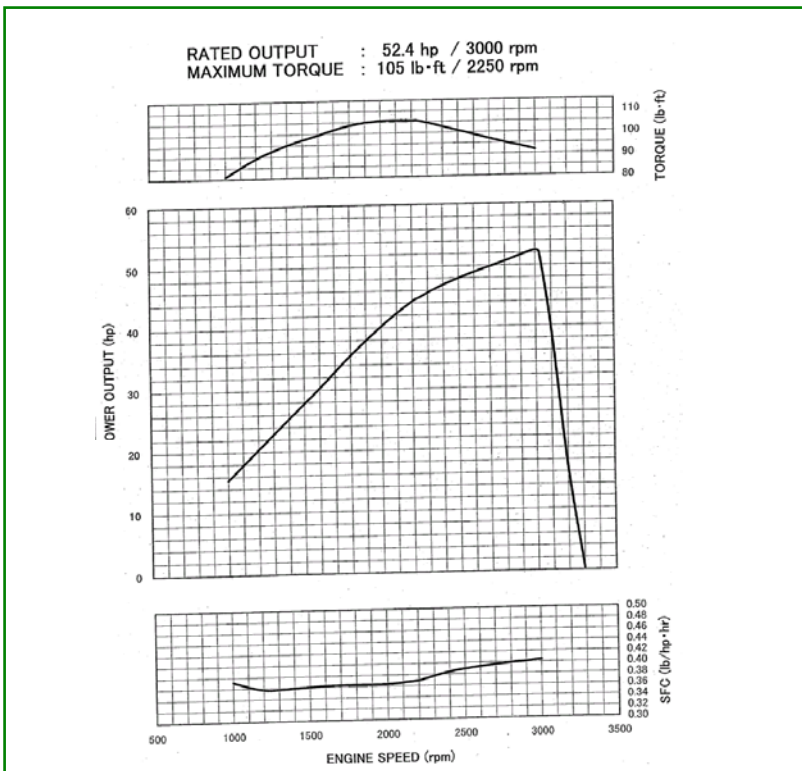

ISUZU MOTORS AMERICA, INC.
PowerTrain Division

ISUZU
DIESEL

46401 Commerce Center Drive • Plymouth, MI 48170
PHONE: 734.582.9470 • FAX: 734.455.7581
www.isuzuengines.com



Blue Ridge Diesel
1016 Delaware Street
P.O. Box 867, Salem, VA 24153

PHONE (540) 389-7296 - FAX (540) 387-2792



Blue Ridge Diesel is one of the leading import diesel engine houses on the east coast of the U.S. Our sales department personnel are qualified to assist you in the proper sizing and selection of an engine for your application. Whether you are working with industrial, construction, agricultural, marine, or mining equipment, our knowledgeable people can help in many ways. From equipment repowering to specifying an engine for new equipment, our competent sales staff is ready to assist you and answer any questions you may have.

Contact Info:

info@blueridgediesel.com

540-389-7296



Blue Ridge Diesel
1016 Delaware Street
P.O. Box 867, Salem, VA 24153

PHONE (540) 389-7296 - FAX (540) 387-2792

