



# TCD 2.9

**Engine for Industrial Applications**

**28 - 55.9 kW | 38 - 75 hp at 2600 min<sup>-1</sup> | rpm**

**EU Stage III B / US EPA Tier 4 interim**

The engine company.



# Characteristics

4 cylinder in-line engines turbocharged, with or without charge air cooler | Water-cooled | Compact engine design | Advanced fuel injection and combustion system | External cooled exhaust gas recirculation | Full line customized options | Excellent cold starting ability for extreme climatic conditions | Full power at flywheel end for axial or radial drives | Optional side PTO from gear end cover | In compliance to non-road emission standards EU Stage III B and US EPA Tier 4 interim

## Your Benefits

- Compact 4 cylinder engine with high specific power and torque, a market leader in engine performance, specially designed for short and narrow machine installations.
- The modern common rail fuel injection system, the rear gear drive and optional balancer shafts guarantee low noise, low vibration and smooth engine operation under all load conditions.
- Engine variant, without aftertreatment but with otherwise identical installations parameters, providing flexibility for export markets with lower emission requirements.
- Low fuel consumption via high pressure Common Rail system, 500 hr oil change interval and the maintenance free valve train provide durable productivity and life long low operating cost.
- A modular exhaust aftertreatment system tailored to meet the requirements of construction equipment with respect to compact installation and competitive cost: the Diesel Oxidation Catalyst (DOC) and the Particulate Oxidation Catalyst (POC) cover most applications; a closed DPF option (Diesel Particulate Filter) is available.
- Low fuel consumption, recyclable components and fluid change friendly systems, designed to protect the environment.
- The extensive network of DEUTZ distributors and dealers providing excellent technical back up and enviable global brand presence.

## Engine Specifications

Cylinder:	4 cylinder in-line
Cooling system:	Water-cooled, belt driven water pump with integrated, thermostat controlled bypass
Crankcase:	Ribbed, thin-wall grey cast iron, noise-optimised
Crankcase breather:	Closed-circuit system
Cylinder head:	Grey-cast iron, U-flow design, 2 valves per cylinder
Valve train:	Overhead valves in cylinder head, two valve per cylinder, actuated via rocker arms, push rods and hydraulic tappets, driven by low-noise straight cut gears and camshaft.
Charging:	Wastegate turbo charger and air-to-air charge cooling version
Piston:	3-ring piston with oil jet cooling
Connecting rod:	Drop-forged steel rod, fracture split
Crankshaft:	High grade SG iron, fillet-rolled, casted counterweights, tri-metal shell bearings
Camshaft:	Steel
Lubrication system:	Gear driven oil rotor pump, integrated oil cooler with spin-on cartridge filter
Fuel injection system:	High pressure Common Rail, electronically controlled
Fuel filter:	Replaceable cartridge main filter and a pre-filter with water trap
Fuel lift pump:	Electrical pump
Alternator:	Three-phase alternator, 14 V / 55 - 120 A (depending on application)
Starter motor:	12 V / 2.6 kW
Options:	Intake manifold connections, exhaust manifolds connections, hydraulic pumps drives, mass balancing shafts, engine mounts, multi oil pan drains, dipsticks, SAE flywheel housings, flywheels, oil filter position horizontal, vertical and remote, oil filler in cylinder head cover and low level fill on side of crankcase, electrics 12 V and 24 V

# Technical Data

Engine model		D 2.9 L4	TD/TCD 2.9 L4
Number of cylinders		4	4
Bore/stroke	mm   in	92/110   3.6/4.3	92/110   3.6/4.3
Displacement	l   cu in	2.92   178	2.92   178
Compression ratio		1 : 19.2	1 : 17
Rated speed	min <sup>-1</sup>   rpm	3000	2600
Mean piston speed	m/s   ft-m	11.0   2165	9.5   1877

## EU Stage III B/US EPA Tier 4

Power ratings <sup>1)</sup>		D 2.9 L4	TD/TCD 2.9 L4
Power acc. to ISO 14396	kW   hp	36.9 (36.4 <sup>3)</sup>   50	55.9 (55.4 <sup>3)</sup>   75
at engine speed	min <sup>-1</sup>   rpm	3000	2600
mean effective pressure	bar   psi	5.1   186	8.8   128
Max. torque	Nm   ft-lb	147   108	252   186
at engine speed	min <sup>-1</sup>   rpm	1600	1600
Minimum idle speed	min <sup>-1</sup>   rpm	900	900
Weight acc. to DIN 70020, Part 7A <sup>2)</sup>	kg   lbs	210 <sup>2)</sup>   463 <sup>2)</sup>	225 <sup>2)</sup>   496 <sup>2)</sup>

1) Power ratings at flywheel gross, without cooling system

2) Not including starter motor/alternator, radiator and operating fluids but including flywheel and flywheel housing.

3) Power rating for US EPA Tier 4

The figures indicated in this datasheet are for informational purposes only and are not binding.  
The specifications in the quote are determinative.

## Standard Engines

### D 2.9 L4

3000 min<sup>-1</sup> | rpm

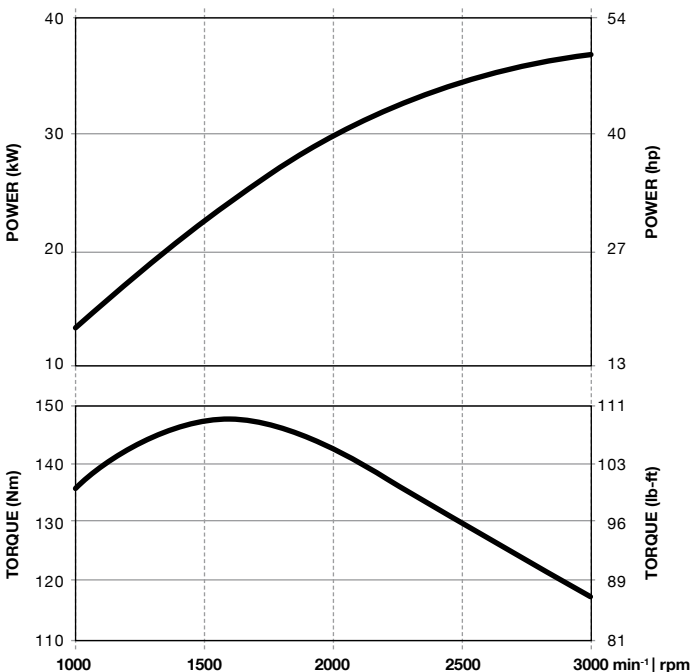

### TD/TCD 2.9 L4

2600 min<sup>-1</sup> | rpm

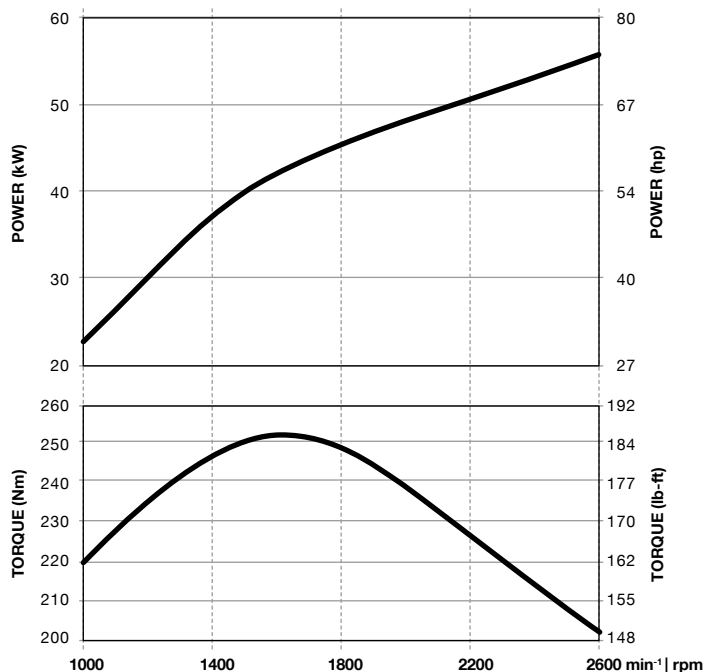

Dimensions		A	B	C
D 2.9 L4	mm   in	652   25.7	477   18.8	695   27.4
TD/TCD 2.9 L4	mm   in	652   25.7	552   21.7	695   27.4

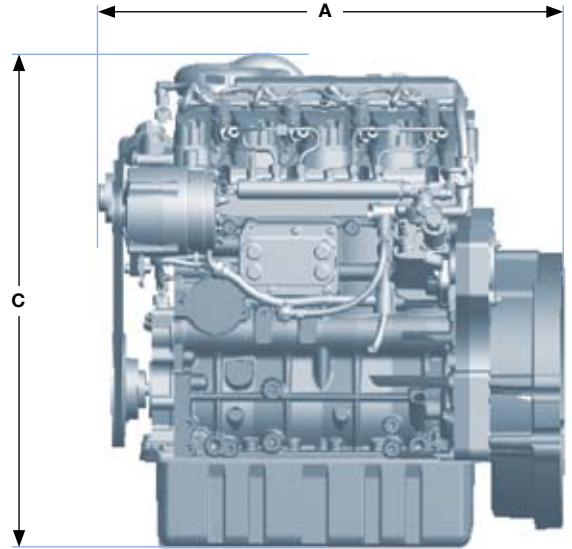
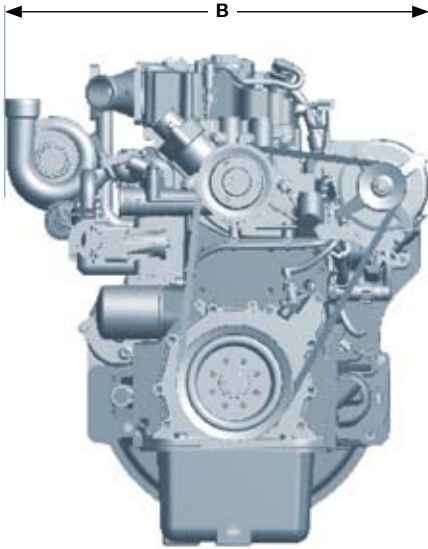

## Tier 4 – our driving force, your advantage.

Starting January 2013, diesel engines of mobile construction machines with power classes ranging < 56 kW have to meet European regulations on exhaust emissions according to EU Stage III B or US EPA Tier 4. The considerable reduction in particulate matter and NO<sub>x</sub> requires that engines be equipped with additional exhaust emission treatment equipment.

### **The individual solution counts**

Our goal as engine specialists is to provide our customers with engines that not only meet all of their performance needs but also comply with the various emission regulations worldwide while meeting their demands for efficient and economical engine operation. We are therefore developing solutions oriented to meet individual customer requirements. The modular DVERT® system developed by DEUTZ enables us to implement different emission-reducing technologies specifically tailored to fulfil those requirements while maintaining the performance of our engines, which include high fuel economy, dependability, and long life.

The Diesel Oxidation Catalyst (DOC) combined with an open Diesel Particulate Filter (POC) is one of the DVERT® modules we use. This is the standard technology we implement for TCD 2.9 L4-series complying with the EU exhaust emission legislation Stage III B and the US EPA Tier 4.

For special applications and load profiles DEUTZ also offers the possibility to use a DOC and a closed Diesel Particulate Filter (DPF) with throttle regeneration.

### **Operation mode and Regeneration of the Diesel Particulate Filter**

The Diesel Oxidation Catalyst (DOC) initially oxidizes gaseous pollutants such as HC, CO, and NO. Soot particulates are then captured in an enclosed Diesel Particulate Filter installed after the catalytic converter.

A continuous catalytic reaction regenerates the filter.

The NO<sub>2</sub> produced in the DOC oxidizes in the Diesel Particulate Filter (POC or DPF) thereby generating the temperature required to burn off the deposits of soot.

This type of filter regeneration is possible for virtually all load patterns and represents by far the most cost-effective solution.

In case of a DPF installation in combination with low exhaust temperatures, the regeneration is actively supported by an electronically controlled intake air throttle to achieve the temperature level required for the regeneration.

DEUTZ worldwide:

[www.deutz.com](http://www.deutz.com)



**DEUTZ AG**

Ottostr. 1  
51149 Cologne, Germany  
Phone: +49 (0) 221 822-0  
Telefax: +49 (0) 221 822-3525  
E-Mail: [info@deutz.com](mailto:info@deutz.com)  
[www.deutz.com](http://www.deutz.com)

**DEUTZ Corporation**

3883 Steve Reynolds Blvd.  
Norcross, GA 30093, USA  
Phone: +1 770 564 7100  
Telefax: +1 770 564 7222  
E-Mail: [engines@deutzusa.com](mailto:engines@deutzusa.com)  
[www.deutzusa.com](http://www.deutzusa.com)

**DEUTZ AG Beijing Office**

207 CITIC Building  
Jian Guo Men Wai Dajie,  
100004 Beijing, P.R. China  
Phone: +86 10 65 00 64 44  
Telefax: +86 10 65 12 00 42  
E-Mail: [dbj@deutz.com.cn](mailto:dbj@deutz.com.cn)  
[www.deutz.com.cn](http://www.deutz.com.cn)

**DEUTZ Asia-Pacific (Pte) Ltd.**

11 Kian Teck Road  
628768 Singapore  
Phone: +65 62 68 53 11  
Telefax: +65 62 64 17 79  
E-Mail: [dap@deutz.com](mailto:dap@deutz.com)  
[www.deutz.com](http://www.deutz.com)

**DEUTZ Australia Pty. Ltd.**

41 Woodlands Drive  
3195 Braeside Vic, Australia  
Phone: +61 3 9586 9600  
Telefax: +61 3 9580 4090  
E-Mail: [deutzoz@deutz.com](mailto:deutzoz@deutz.com)  
[www.deutz.com](http://www.deutz.com)

The engine company. 



**Blue Ridge Diesel**  
1016 Delaware Street  
P.O. Box 867, Salem, VA 24153

PHONE (540) 389-7296 - FAX (540) 387-2792



**Blue Ridge Diesel** is one of the leading import diesel engine houses on the east coast of the U.S. Our sales department personnel are qualified to assist you in the proper sizing and selection of an engine for your application. Whether you are working with industrial, construction, agricultural, marine, or mining equipment, our knowledgeable people can help in many ways. From equipment repowering to specifying an engine for new equipment, our competent sales staff is ready to assist you and answer any questions you may have.

**Contact Info:**

[info@blueridgediesel.com](mailto:info@blueridgediesel.com)

540-389-7296



**Blue Ridge Diesel**  
1016 Delaware Street  
P.O. Box 867, Salem, VA 24153

PHONE (540) 389-7296 - FAX (540) 387-2792

