



TCD 2013

Engine For Agricultural Equipment

172–261 kW | 214–355 hp at 2200 min⁻¹ | rpm

EU Stage III B / US EPA Tier 4 interim

The engine company.



Tier 4 – our driving force, your advantage.

Starting January 2011, diesel engines of mobile construction machines with power classes ranging from 130 to < 560 kW must meet European regulations on exhaust emissions according to EU Stage III B and US EPA Tier 4 interim. These emission standards will require considerable reductions in particulate matter and NO_x emissions.

Accordingly, our engines will be receiving additional exhaust emission treatment equipment that is adapted to the respective combustion principle.

The individual solution counts

Our goal as engine specialists is to provide our customers with engines that not only meet all of their power needs but also comply with the various emission regulations worldwide while meeting their demands for efficient and economical engine operation to the greatest possible extent.

The modular DVERT® system developed by DEUTZ enables us to implement different emission-reducing techniques specifically tailored to fulfill individual customer requirements while maintaining the proverbial criteria of our engines, which include high economy, dependability, and long life.

Selective catalytic reduction (SCR) is one of the standard DVERT® modules we use to highly efficiently reduce the NO_x emissions of our 2013-series engines, beginning with exhaust emission stages III B and EPA Tier 4 interim.

This method does not directly use the ammonia necessary for the selective catalytic reaction but instead injects it as a 35% water-based urea solution into the engine exhaust where the chemical reaction produces ammonia (NH₃) and carbon dioxide (CO₂). At the corresponding temperature, the ammonia formed in the SCR catalytic converter reacts with and reduces the nitrogen oxide (NO_x) in the exhaust. The amount of urea solution injected by a special injection nozzle depends on the amount of nitrogen oxide currently present at the engine operating point and thus the respective load and rpm. The urea consumption thus depends on the collective engine load and can range between 2% and 5% of the engine fuel consumption.

Higher performance and dynamics – lower fuel consumption

The customer benefits from using the SCR method in the 2013-series in that fuel and lubricating oil consumption remains at known low levels for his machines and no extra expense incurs for engine cooling. The SCR process, in conjunction with optimized injection and combustion technology, makes it possible to reduce particulate emission limits solely with the help of engine modifications.

DVERT® – solutions for the future

Only after exhaust emission stage EU IV / US EPA Tier 4 takes effect, will it be necessary to equip engines of this model series with combined particulate filter and DeNO_x technology.

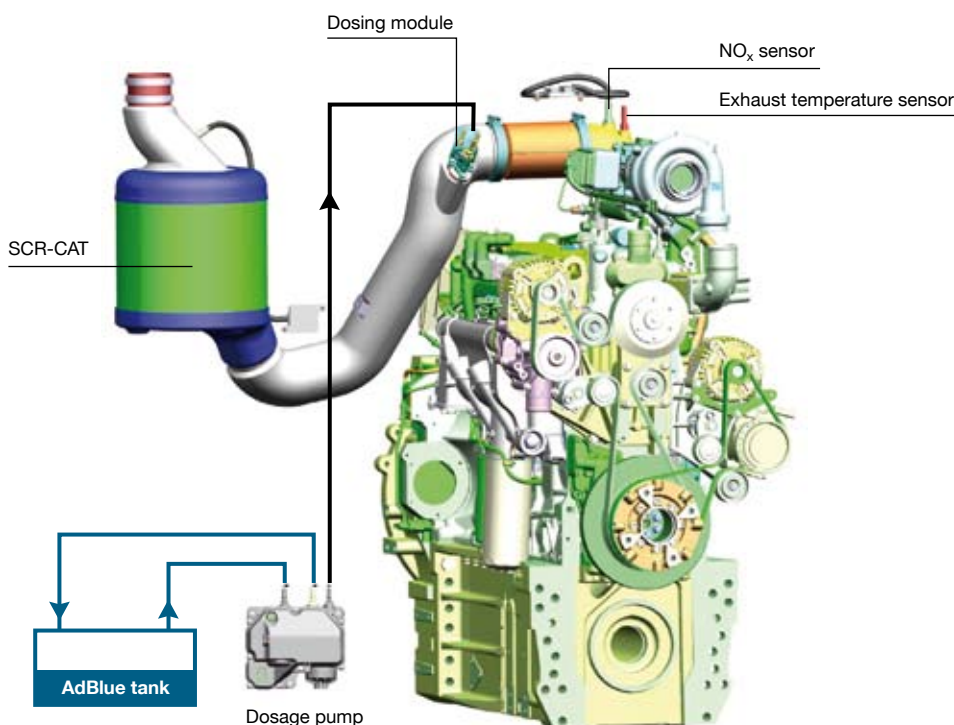

Characteristics

Modern, liquid-cooled 6-cylinder in-line engine | Turbocharged with intercooler (air/air) | High-performance, rugged engine with a high power density | Power take-off capabilities integrated in the gear train | Electronic engine control with intelligent adaptation to drive management | High-pressure fuel injection with DEUTZ's Common Rail System (DCR®) | SCR Exhaust aftertreatment

Your Benefits

- Highly economical due to very good fuel economy, simple and cost-effective installation, and long service intervals.
- Low noise emissions eliminate the need for costly additional sound insulation.
- Slender engine design and variable layout of the front end of the engine offer maximum flexibility.
- With the DVERT® platform, the 2013 is prepared for future EU Stage IV and US EPA Tier 4 exhaust emission stages.
- The compelling performance of the smooth running engine guarantees great driving comfort.
- The 2013 complies with emissions controls for mobile machinery in accordance with EU Nonroad 2004/26/EU Stage III B and US EPA Tier 4 interim.

Engine Specifications

Type of cooling:	Liquid cooling
Crankcase/cylinders:	Gray cast iron housing, wet cylinder sleeves
Crankcase ventilation:	Open
Cylinder head:	Modular design, gray cast iron cylinder head
Valve arrangement / control:	Overhead in the cylinder head, two intake and exhaust valves per cylinder, actuated by tappets, pushrods, and rockers. Control is driven by camshaft running in binary bearings
Pistons:	Triple-ring pistons, two compression rings, one oil ring
Piston cooling:	Injected cooling oil
Turbocharging:	Wastegate turbocharger with charge air intercooler (air/air).
Connecting rod:	Drop-forged steel
Crankshaft bearings:	Ternary bearings, one of which thrust bearing
Piston rod bearings:	Quarterternary/ternary friction bearings
Crankshaft:	Drop-forged steel
Camshaft:	Steel, running in binary bearings
Camshaft drive:	By the crankshaft by straight, high-g geared spur gears
Lubrication:	Forced-feed lubrication
Lubricating oil cooler:	External
Lubricating oil filter:	Replaceable paper microfilter cartridge in main lubricating oil flow
Injection pump / controller:	Two high-pressure unit pumps
Fuel supply pump:	Gear pump in gear train
Injector:	8-hole injection nozzle
Fuel filter:	Replaceable paper microfilter cartridge
Alternator:	Three-phase alternator 14 V, 150 A (standard)
Starter:	12 V / 4 kW (standard)
Heating system:	Optional connection for cab heating
Options for adapting to specific equipment requirements:	Hydraulic pumps, connection housing, oil pans, fan attachments, air-conditioning compressor, alternators

Technical Data

Engine model		TCD 2013 L6 4V
Number of cylinders		6
Bore/stroke	mm in	110/136 4.33/5.35
Displacement	l cu in	7.75 473
Compression ratio		18,1 : 1
Rated RPM	min ⁻¹ rpm	2200
Mean piston speed	m/s ft-m	10.0 1963

EU Stage III B / US EPA Tier 4 interim

Power ratings for mobile construction machines ¹⁾		TCD 2013 L6 4V
Power output acc. to ISO 14396	kW hp	261 350
at engine speed	min ⁻¹ rpm	2100
Max. power	kW hp	269 360.7
At speed	min ⁻¹ rpm	1900 2100
At mean effective pressure	bar psi	19.23 279
Max. torque	Nm lb-ft	1498 1105
at engine speed	min ⁻¹ rpm	1500
Minimum idle speed	min ⁻¹ rpm	600
Specific fuel consumption ²⁾	g/kWh lb/hp-hr	198 0.33
Weight	kg lb	1246 2747

1) Power ratings without deducting fan power consumption

2) Best WOT consumption based on diesel fuel with a density of 0.835 kg/dm³ at 15 °C.

3) Without starter/alternator, cooling system and liquids but with flywheel and flywheel housing

The figures indicated in this datasheet are for informational purposes only and are not binding. The specifications in the quote are determinative.

Standard Engine

TCD 2013 L6 4V

2200 min⁻¹ | rpm

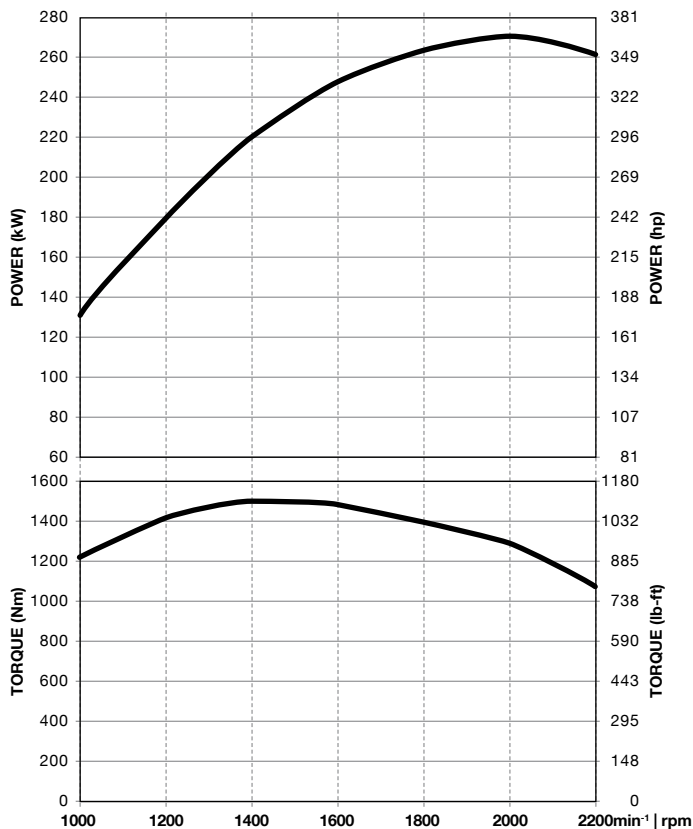

Dimensions

TCD 2013 L6 4V

mm | in

A

1256 | 49.4

B

700 | 27.6

C

1355 | 53.3

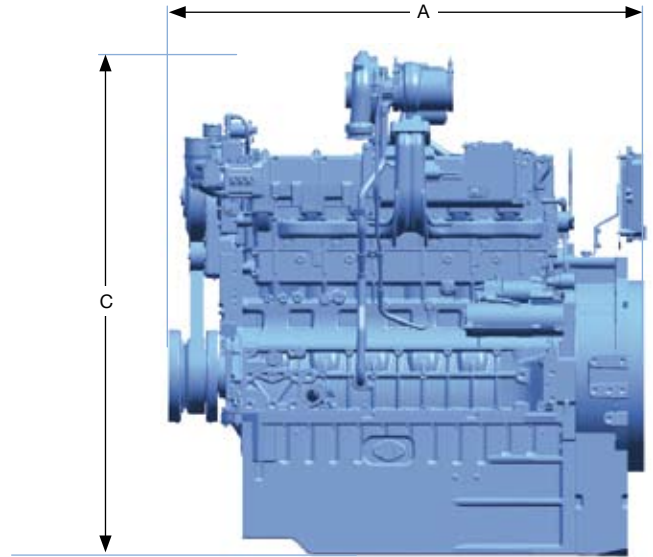

DEUTZ worldwide:

www.deutz.com



DEUTZ AG

Ottostr. 1
51149 Cologne, Germany
Phone: +49 (0) 221 822-0
Telefax: +49 (0) 221 822-3525
E-Mail: info@deutz.com
www.deutz.com

DEUTZ Corporation

3883 Steve Reynolds Blvd.
Norcross, GA 30093, USA
Phone: +1 770 564 7100
Telefax: +1 770 564 7222
E-Mail: engines@deutzusa.com
www.deutzusa.com

DEUTZ AG Beijing Office

207 CITIC Building
Jian Guo Men Wai Dajie,
100004 Beijing, P.R. China
Phone: +86 10 65 00 64 44
Telefax: +86 10 65 12 00 42
E-Mail: dbj@deutz.com.cn
www.deutz.com.cn

DEUTZ Asia-Pacific (Pte) Ltd.

11 Kian Teck Road
628768 Singapore
Phone: +65 62 68 53 11
Telefax: +65 62 64 17 79
E-Mail: dap@deutz.com
www.deutz.com

DEUTZ Australia Pty. Ltd.

41 Woodlands Drive
3195 Braeside Vic, Australia
Phone: +61 3 9586 9600
Telefax: +61 3 9580 4090
E-Mail: deutzoz@deutz.com
www.deutz.com

The engine company. 



Blue Ridge Diesel
1016 Delaware Street
P.O. Box 867, Salem, VA 24153

PHONE (540) 389-7296 - FAX (540) 387-2792



Blue Ridge Diesel is one of the leading import diesel engine houses on the east coast of the U.S. Our sales department personnel are qualified to assist you in the proper sizing and selection of an engine for your application. Whether you are working with industrial, construction, agricultural, marine, or mining equipment, our knowledgeable people can help in many ways. From equipment repowering to specifying an engine for new equipment, our competent sales staff is ready to assist you and answer any questions you may have.

Contact Info:

info@blueridgediesel.com

540-389-7296



Blue Ridge Diesel
1016 Delaware Street
P.O. Box 867, Salem, VA 24153

PHONE (540) 389-7296 - FAX (540) 387-2792

