

# TD 2011

The Construction Equipment Engine. 23–56 kW | 31–75 hp at 1600–2800 rpm

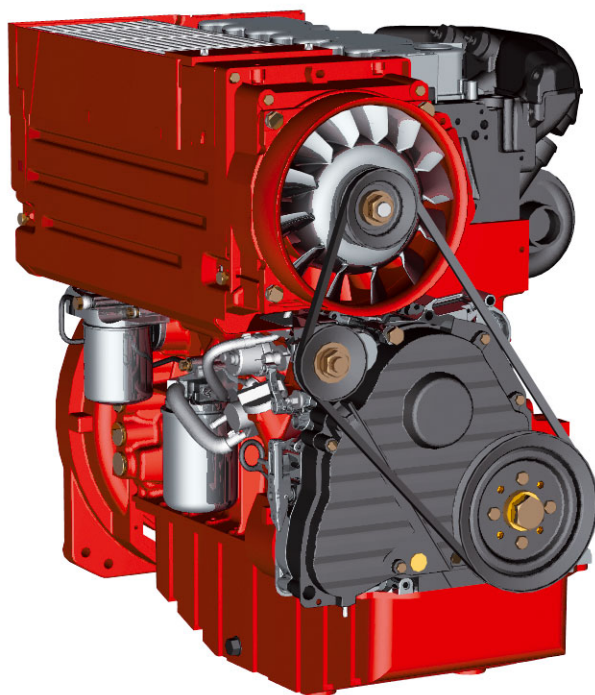

The engine company.



# Your benefits

- Compact dimensions. Takes up less space and reduces installation costs.
- The 2011 model series offers an outstanding power-to-weight ratio.
- Low exhaust emissions for a clean environment. Compliance with 2004/26/EU level III A and EPA TIER III for mobile equipment.
- High reliability combined with long maintenance intervals and low wear.
- Low noise emission eliminates the need for costly noise-reducing soundproofing measures.

# Characteristics

Compact dimensions | Naturally-aspirated 2-, 3- and 4-cylinder in-line engines | Turbocharging also for 4-cylinder engines | With integrated cooling system | Power take-offs for driving hydraulic pumps up to 28 kW/2800 rpm | All service points located on one side of the engine

## TIER III/level III A performance for mobile working machines <sup>1)</sup>

Engine model		D 2011 L2 i	D 2011 L3 i	D 2011 L4 i	TD 2011 L4 i
Number of cylinders		2	3	4	4
Bore/stroke	mm   inch	94/112   3.7/4.4	94/112   3.7/4.4	96/125   3.8/5.0	96/125   3.8/5.0
Swept volume	l   cu inch	1.55   95	2.33   142	3.62   221	3.62   221
Compression ratio		1 : 19	1 : 19	1 : 19	1 : 18
Max. rated speed	rpm	2800	2800	2600	2600
Mean piston speed	m/s   ft/sec	10.5   34.4	10.5   34.4	10.5   34.4	10.5   34.4

## Performance for mobile working machines <sup>1)</sup>

Output according to ISO 14396	kW   hp	23   31	35.8   48	46   62	56   75
At engine speed	rpm	2800	2800	2600	2600
At mean, effective pressure	bar   lb/inch	6.3   91	6.6   96	6.1   88	7.4   107
Max. torque	Nm   lb/ft	90   66	137   101	190   140	250   184
At engine speed	rpm	1700	1700	1700	1600
Minimum idle speed	rpm	900	900	900	900
Specific fuel consumption <sup>2)</sup>	g/kWh   lb/hp-hr	225   0.37	225   0.37	230   0.38	230   0.38
Weight according to DIN 70020, Part 7A <sup>3)</sup>	kg   lb	175   386	217   478	270   595	267   589

## Dimensions

in mm   inch	A	B	C
D 2011 L2 i	487   19.2	451   17.8	683   26.9
D 2011 L3 i	599   23.6	451   17.8	678   26.9
D 2011 L4 i	710   28.0	467   18.4	713   28.1
TD 2011 L4 i	710   28.0	530   20.9	713   28.1

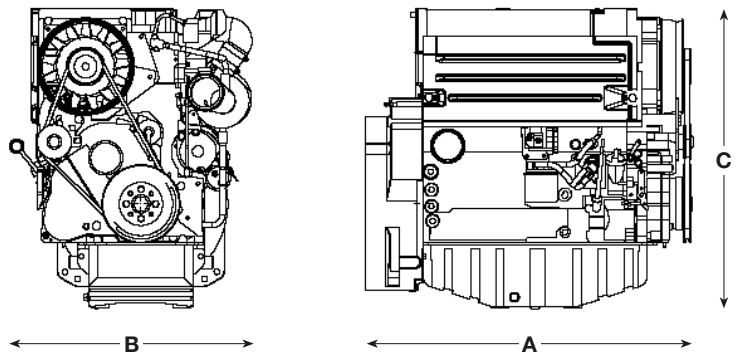

1) Gross flywheel output data including integrated cooling system.

2) At best point. Specific fuel consumption with reference to diesel fuel with a density of 0.835 kg/dm<sup>3</sup> at 15 °C (6.96 lb/US gallon at 60 °F).

3) Including integrated cooling system, flywheel and SAE housing, but without starter motor, alternator and fluids.

The values specified in this datasheet are for information purposes only and are not binding.

The information given in the quotation is decisive.



**Blue Ridge Diesel**  
1016 Delaware Street  
P.O. Box 867, Salem, VA 24153

PHONE (540) 389-7296 - FAX (540) 387-2792



**Blue Ridge Diesel** is one of the leading import diesel engine houses on the east coast of the U.S. Our sales department personnel are qualified to assist you in the proper sizing and selection of an engine for your application. Whether you are working with industrial, construction, agricultural, marine, or mining equipment, our knowledgeable people can help in many ways. From equipment repowering to specifying an engine for new equipment, our competent sales staff is ready to assist you and answer any questions you may have.

**Contact Info:**

[info@blueridgediesel.com](mailto:info@blueridgediesel.com)

540-389-7296



**Blue Ridge Diesel**  
1016 Delaware Street  
P.O. Box 867, Salem, VA 24153

PHONE (540) 389-7296 - FAX (540) 387-2792

